

Spiebaan tabel volgens DIN 6885

As

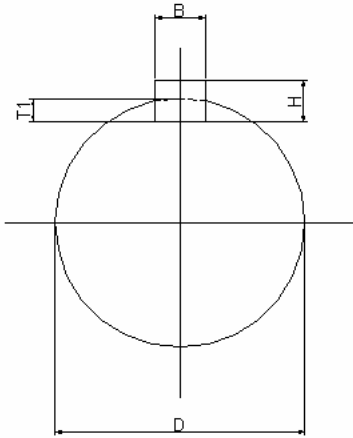

Boring

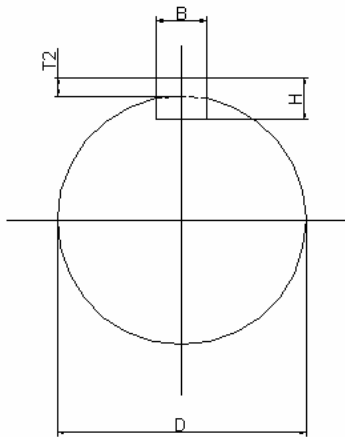

Asdiameter D		Spie afmeting B x H	Spiebaan_afmeting in as T1		Spiebaan_afmeting in boring T2	
van	t/m		Diepte	Tolerantie	Diepte	Tolerantie
			Zware passing P9 lichte passing N9		Zware passing N9 lichte passing J9	
6	8	2 x 2	1,2	+ 0,1 0	1,0	+ 0,1 0
8	10	3 x 3	1,8		1,4	
10	12	4 x 4	2,5		1,8	
12	17	5 x 5	3,0		2,3	
17	22	6 x 6	3,5		2,8	
22	30	8 x 7	4,0	+ 0,2 0	3,3	+ 0,2 0
30	38	10 x 8	5,0		3,3	
38	44	12 x 8	5,0		3,3	
44	50	14 x 9	5,5		3,8	
50	58	16 x 10	6,0		4,3	
58	65	18 x 11	7,0		4,4	
65	75	20 x 12	7,5		4,9	
75	85	22 x 14	9,0		5,4	
85	95	25 x 14	9,0		5,4	
95	110	28 x 16	10,0		6,4	
110	130	32 x 18	11,0	7,4	+ 0,3 0	
130	150	36 x 20	12,0	8,4		
150	170	40 x 22	13,0	9,4		
170	200	45 x 25	15,0	10,4		
200	230	50 x 28	17,0	11,4		
230	260	56 x 32	20,0	12,4		
260	290	63 x 32	20,0	12,4		
290	330	70 x 36	22,0	14,4		
330	380	80 x 40	25,0	15,4		
380	440	90 x 45	28,0	17,4		
440	500	100 x 50	31,0	19,5		